

Specifications

Output Power HP (kW)	1/2 (0.4)
Phase	3 Phase
Pole	4 Pole
Frame Number	71M

Degrees of Protection	IP 55
Enclosure Construction	Totally-enclosed Fan-cooled
Thermal Class	Class F (155 °C)

Alignment	Vertical
Frame Material	Steel plate

Power Transmission	Direct-couple or Belt Driven
Direction of Rotation	Counterclockwise (CCW) viewed from shaft-end side

Connection Type	Terminal Block (6 Leads)
Coating Colour	Munsell N5.5 (Gray)
Conformed Standard	IEC 60034-1 & JEC-2137-2000

Voltage & Frequency	LT Type	
	220/380~415V	50Hz
	220/440V	60Hz

Motor Characteristics

Type	Hz	V	50% Load			75% Load			100% Load				Torque(%)		Is (A)	Inertia GD ² (kg-m ²)	
			(A)	Eff(%)	PF(%)	(A)	Eff(%)	PF(%)	(A)	Eff(%)	PF(%)	Speed (r/min)	Torque (kg-m)	Ts			Tm
LT	50	220	1.52	0.63	0.55	1.70	0.70	0.66	1.97	0.73	0.74	1410	0.280	336	286	10.2	0.0061
		380	0.88	0.63	0.55	0.98	0.70	0.66	1.13	0.73	0.74	1410	0.280	336	286	5.91	
		415	1.01	0.58	0.47	1.068	0.67	0.58	1.18	0.71	0.66	1430	0.270	413	344	6.50	
	60	220	1.22	0.72	0.60	1.44	0.77	0.72	1.71	0.78	0.79	1700	0.230	295	266	9.49	
		440	0.79	0.66	0.50	0.87	0.73	0.62	0.98	0.75	0.71	1730	0.230	392	354	6.36	

Dimensions (mm)

Flange Number	Motor							
	D	LA	LB	LC	LE	LG	LL	LZ
FF130	148	130	110 j6	160	3.5	10	229	10

Terminal Box			Shaft End						
KD	KG	KL	LR	Q	QK	S	T	U	W
PF 1/2	80	138	30	30	25	14 j6	5	3	5

Bearing No.		Approximated Weight (kg)	Approximated Packing Dimensions (LxWxH)	Gross Weight (kg)
Drive End	Opposite			
6202ZZ	6201ZZ	9.2	318 x 256 x 180	9.8

Connection & Connection Diagram

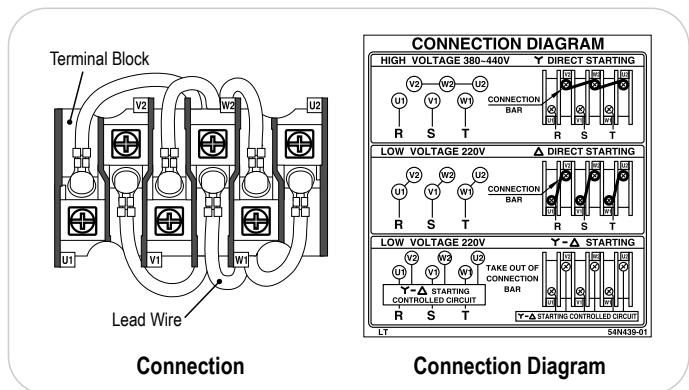

Circumstance Conditions

Ambient Temperature	-20 ~ +40°C
Ambient Humidity	95% RH or less
Operating Altitude	Less than 1,000m above sea level
Environment	No bursting / erosive gas or vapor